

TEMPERATURE MONITOR

WITH ANALOG AND HIGH / LOW
ALARMS OUTPUTS



Features

- Displays actual temperature and alarm values.
- 4 alarm values can be entered: low-low, low, high and high-high temperature alarm.
- Large 17mm (0.67") digits.
- Selectable on-screen engineering units °C - °F - K
- Operational temperature -30°C up to +80°C (-22°F up to 178°F).
- Very compact design for panel mount, wall mount or field mount applications.
- Rugged aluminum field mount enclosure IP67 / NEMA4X.
- Intrinsically Safe Ex II 1 GD EEx ia IIB/IIC T4 T100°C.
- Explosion/flame proof Ex II 2 GD EEx d IIB T5.
- Alarm and analog signal outputs.
- Full Modbus communication RS232/485/TTL.
- Loop or battery powered, 8 - 24V AC/DC or 115 - 230V AC power supply.
- Sensor supply 3.2 / 8.2 / 12 / 24V DC.

Signal output

- Up to 4 free configurable alarm outputs.
- (0)4 - 20mA / 0 - 10V DC according to the temperature.

Signal input

Temperature

- PT100 - 2 or 3 wire.
- (0)4 - 20mA.
- 0 - 10V DC.

Applications

- For applications where continuous temperature measurement and monitoring is important. Also re-transmission of the actual temperature or serial communication is required. Alternative basic model: F040 - F043.

General information

Introduction

The F143 is a versatile temperature indicator with continuous temperature monitoring feature. It offers the facility to set two low temperature and two high temperature alarm values.

If desired, an ignore function can be set up to allow for an incorrect temperature for a certain period of time. Up to four outputs are available to transmit the alarm condition.

A wide selection of options further enhance this model's capabilities, including Intrinsic Safety and full Modbus communication.

Display

The display has large 17mm (0.67") and 8mm (0.31") digits which display the temperature, measuring unit and alarm values. The alarm values can be password protected. On-screen engineering units are easily configured from a comprehensive selection.

Configuration

All configuration settings are accessed via a simple operator menu which can be pass-code protected. Each setting is clearly indicated with an alphanumeric description, therefore avoiding confusing abbreviations. All settings are safely stored in EEPROM memory in the event of sudden power failure.

Analog output signal

The actual temperature is re-transmitted with the (0)4 - 20mA or 0 - 10V DC output signal. The output signal is updated ten times per second with a filter function being available to smoothen out the signal if desired. The output value is user defined in relation to the temperature, e.g. 4mA equals to -20°C and 20mA equals to 250 °C. The output signal can be passive, active or isolated where the passive output type will loop power the F143 as well.

Alarm output

Up to four configurable outputs are available to transmit the alarm condition. You can have e.g. two the same low alarm outputs, one high alarm output and one "all alarms" output. Type OS offers four mechanical relay outputs. However, only two outputs are available in Intrinsically Safe applications. Three outputs are

available in all other configurations. The output signals can be a passive NPN, active PNP or an isolated electro-mechanical relay.

Signal input

The F143 does accept (0)4 - 20mA and 0 - 10V input signals from any type of temperature measurement device. Also a two or three wire PT100 sensor can be used.

Communication

All process data and settings can be read and modified manually or through the Modbus communication link (RS232 / RS485). Full Modbus functionality remains available for the Intrinsically Safe version (TTL).

Hazardous areas

For hazardous area applications, this model has been ATEX certified Intrinsically Safe Ex II 1 GD EEx ia IIB / IIC T4 T100°C with an allowed operational temperature of -30°C to +70°C (-22°F to +158°F). A flame proof enclosure is also available with the rating Ex II 2 GD EEx d IIB T5.

Enclosures

Various types of enclosures can be selected, all ATEX approved. As standard the F143 is supplied in an GRP panel mount enclosure, which can be converted to an IP67 / NEMA 4X GRP field mount enclosure by the addition of a back case. Most popular is our rugged aluminum field mount enclosure with IP67 / NEMA 4X rating. Both European or U.S. cable gland entry threads are available.

Overview application F143

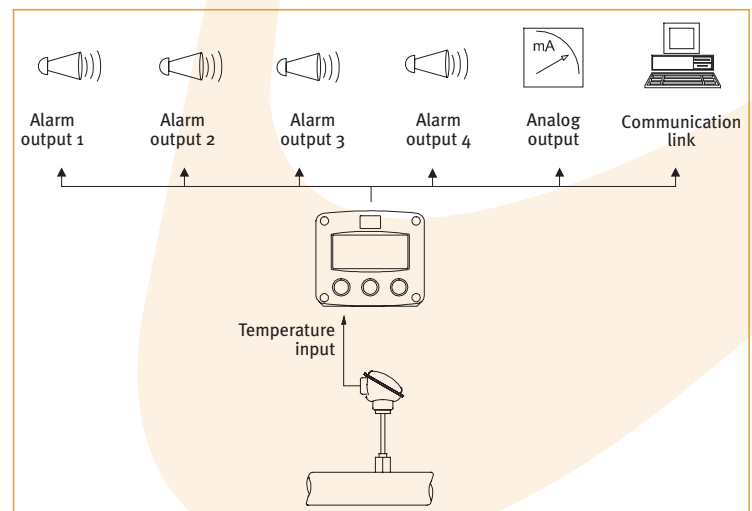

Dimensions enclosures Aluminum & GRP panel mount enclosure

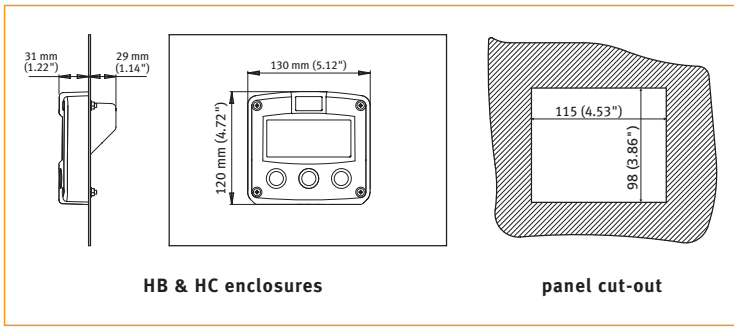

Aluminum & GRP field / wall mount enclosures

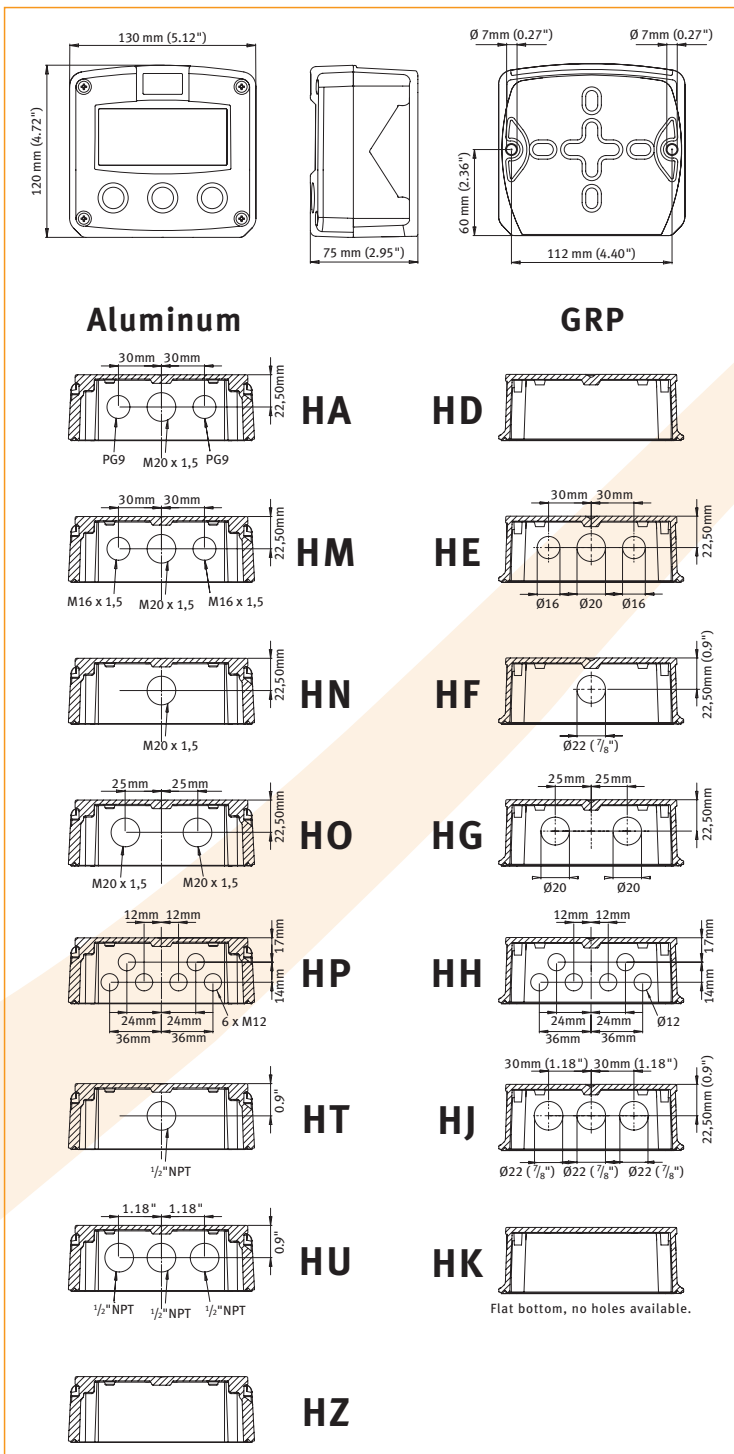

Terminal connections

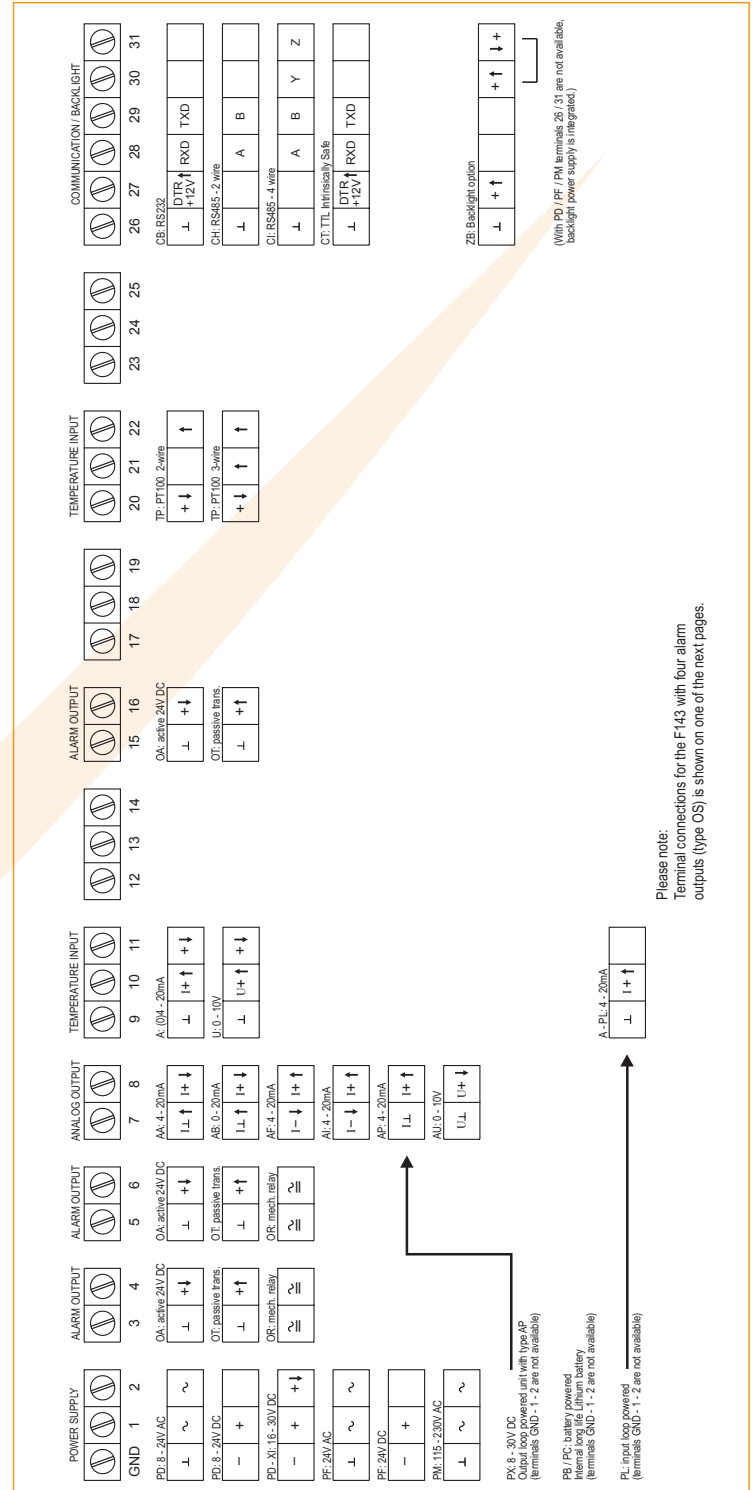

Display example - 90 x 40mm (3.5" x 1.6")



Typical wiring diagram F143-T-AP-CH-OT-PX

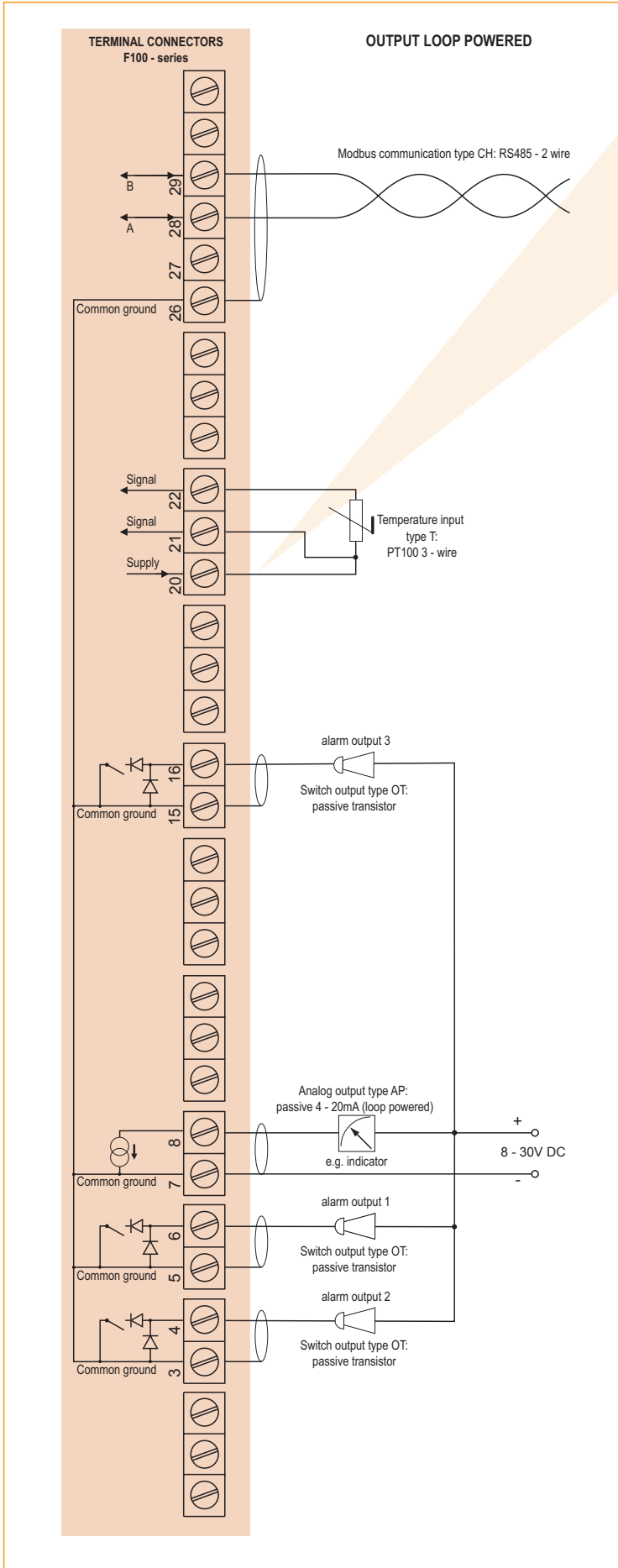

Typical wiring diagram F143-A-AA-CB-OA-PD

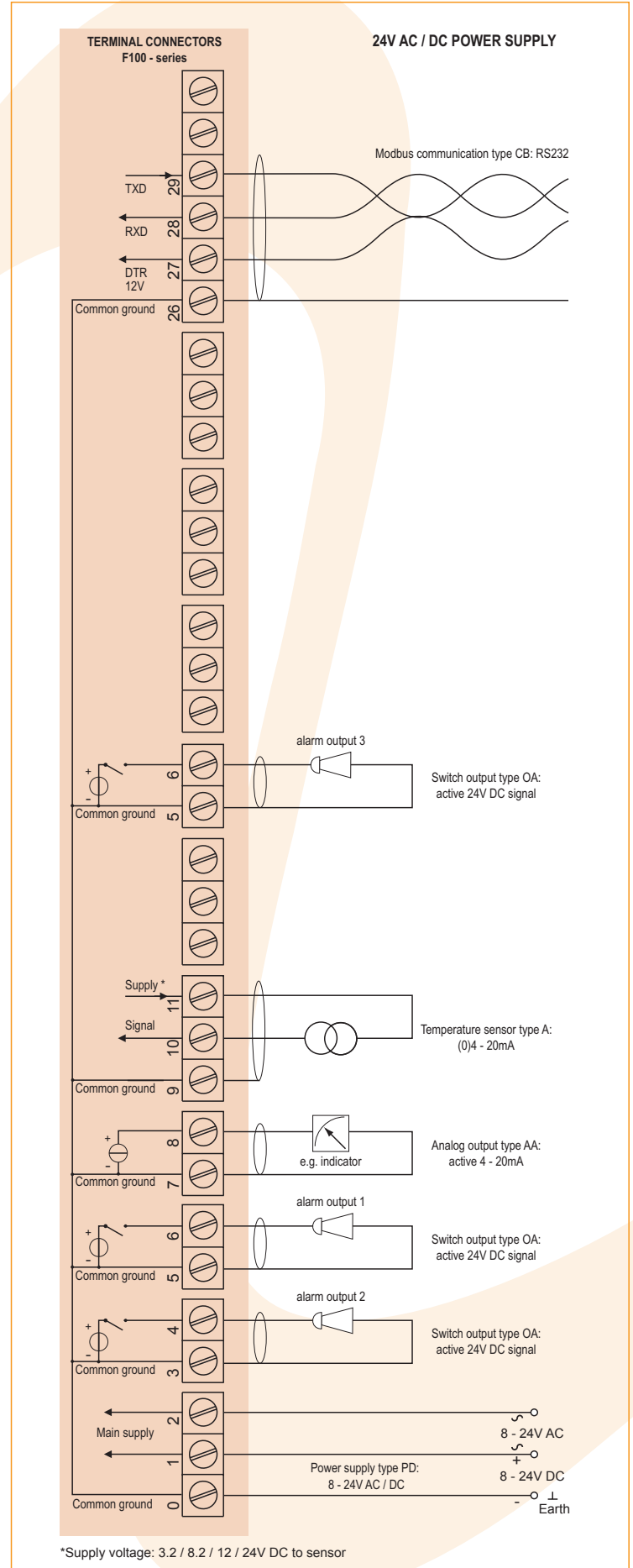

Typical wiring diagram F143-A-AI-CI-OR-PM

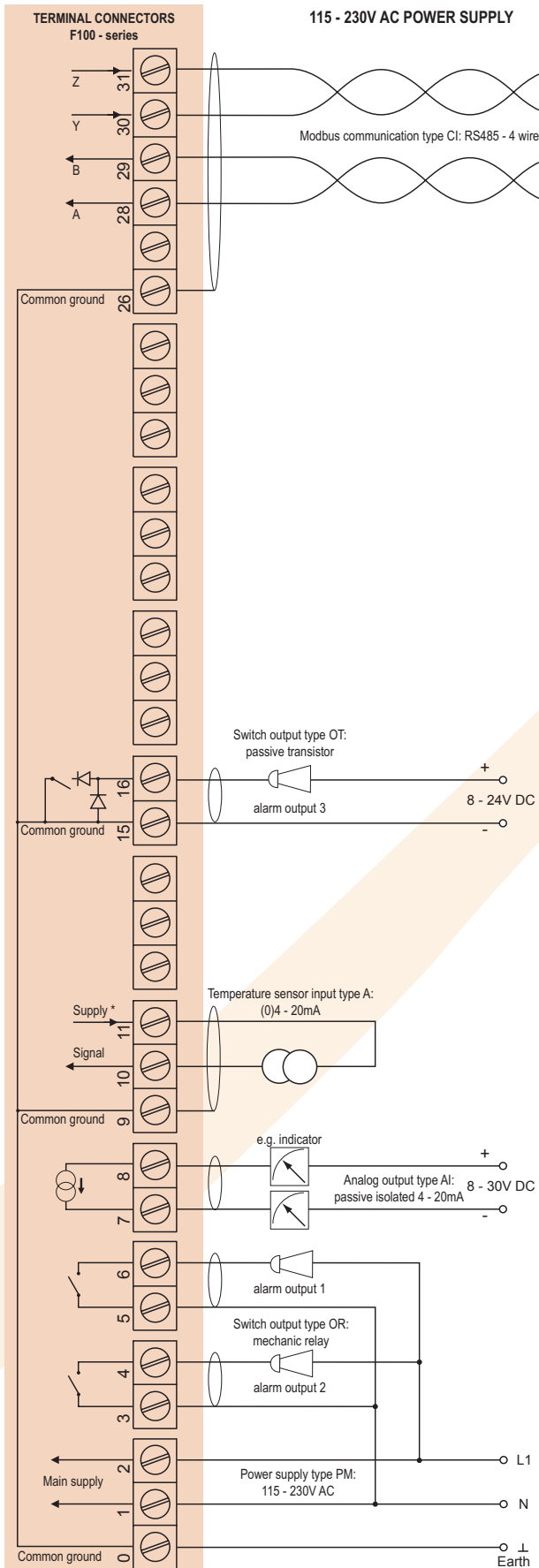

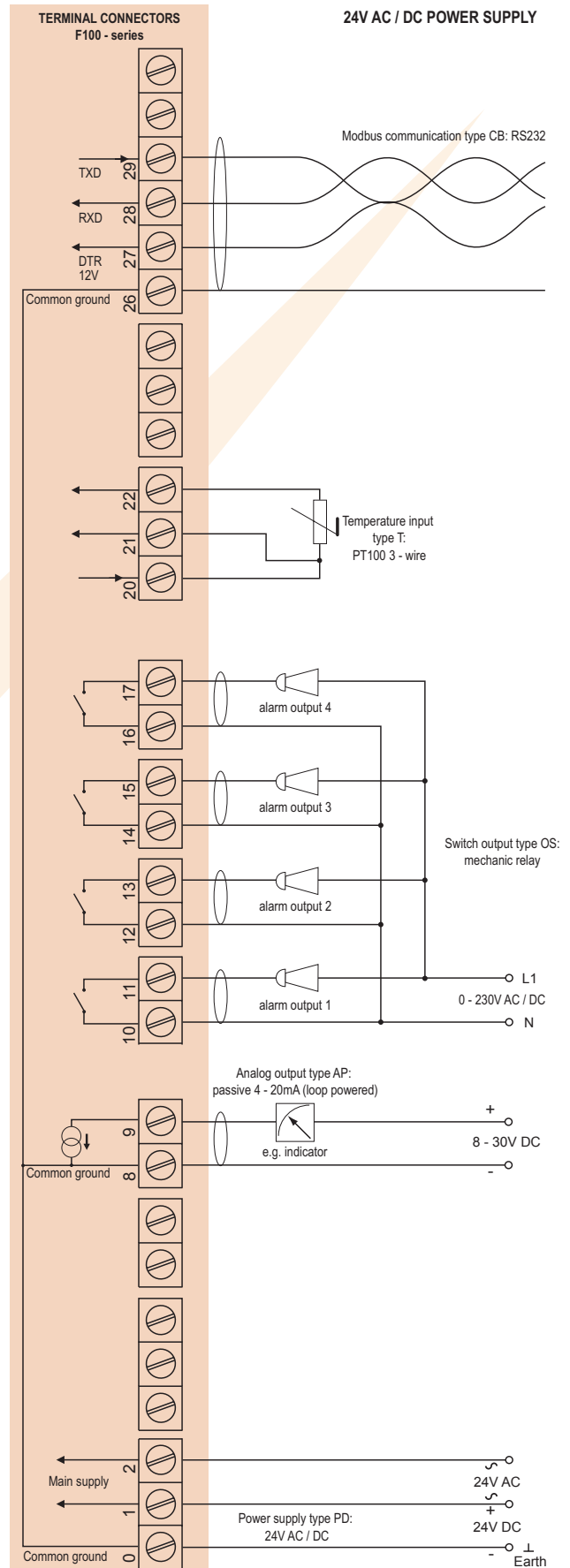

*Supply voltage: 3.2 / 8.2 / 12 / 24V DC to sensor

Typical wiring diagram F143-T-AP-CB-OS-PD



*Supply voltage: 3.2 / 8.2 / 12 / 24V DC to sensor

Hazardous area applications

The F143-XI has been ATEX approved by KEMA for use in Intrinsically Safe applications. It is approved according to  II 1 GD EEx ia IIB/IIC T4 T100°C for gas and dust applications with an operational temperature range of -30°C to +70°C (-22°F to +158°F). Besides the I.S. power supplies for the two alarm outputs, it is allowed to connect up to three I.S. power supplies in IIB applications or one in IIC applications. Full functionality of the F143 remains available, including two alarm outputs and 4 - 20mA output and Modbus communication (type CT). Power supply type PD-XI offers a sensor supply according to the connected power supply voltage at terminal 1. A flame proof enclosure with rating  II 2 GD EEx d IIB T5 is available as well. Please contact your supplier for further details.

Certificate of conformity KEMA 03ATEX1074 X

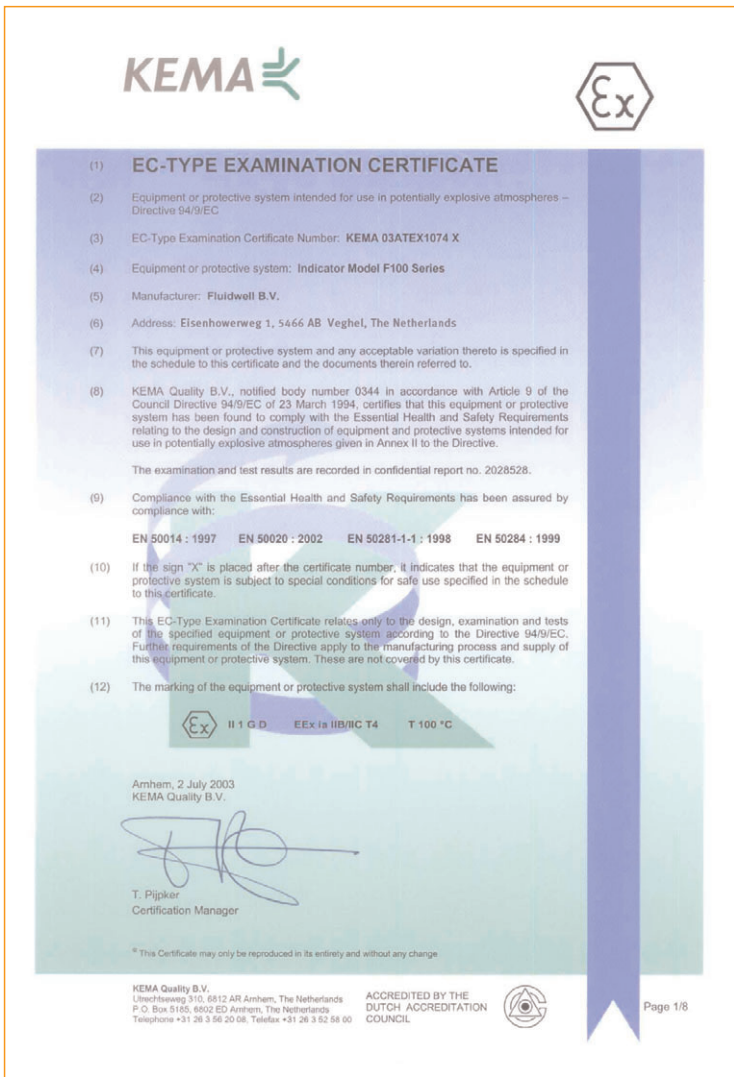

Configuration example IIB and IIC

F143-T-(AP)-(CT)-(OT)-PC-XI - Battery powered unit

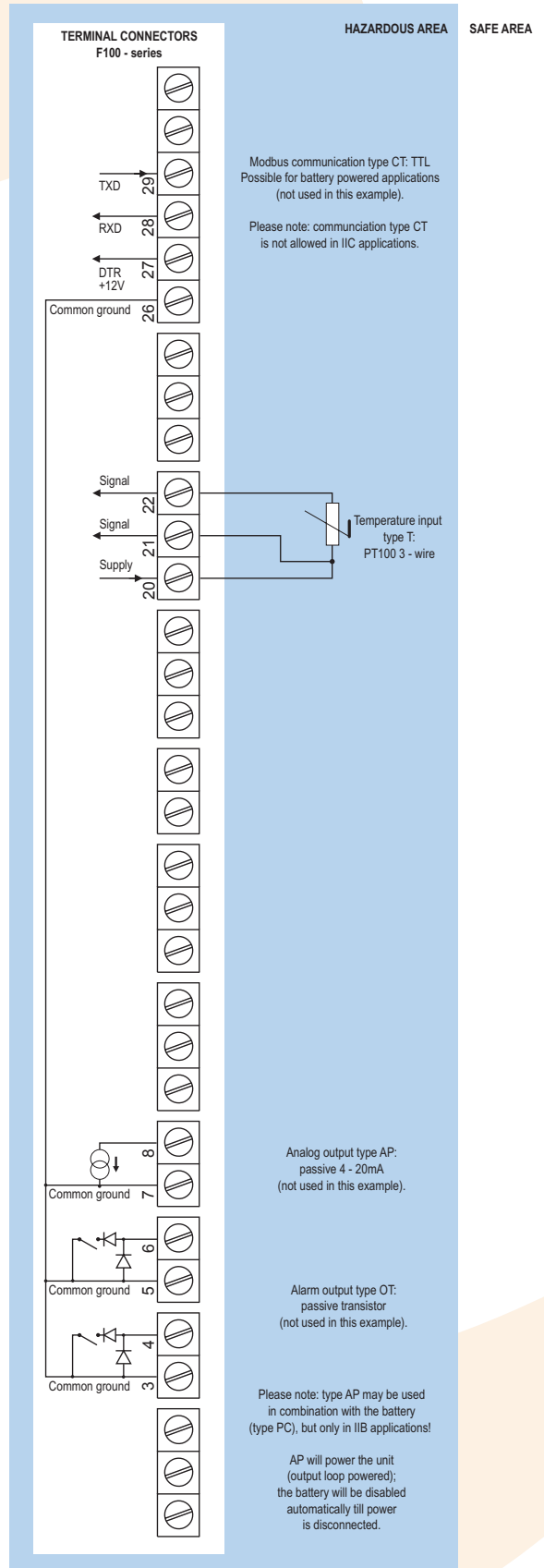

Configuration example IIB - F143-A-AP-CT-OT-PX-XI - Output loop powered

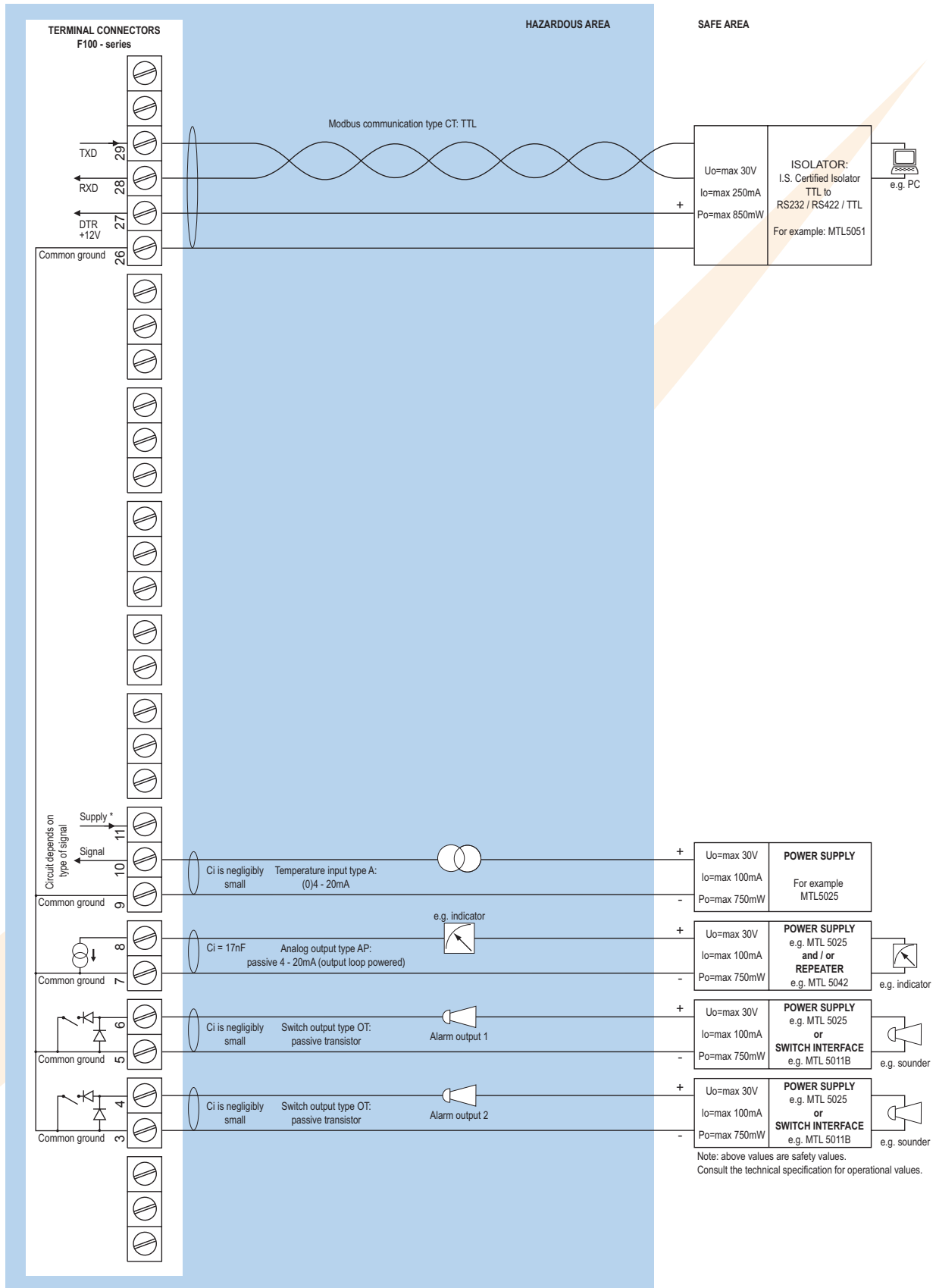

* Note sensor supply voltage: 3.2V DC - not suitable to power analog sensors.

Configuration example IIB - F143-A-AF-CT-OT-PL-XI - Input loop powered

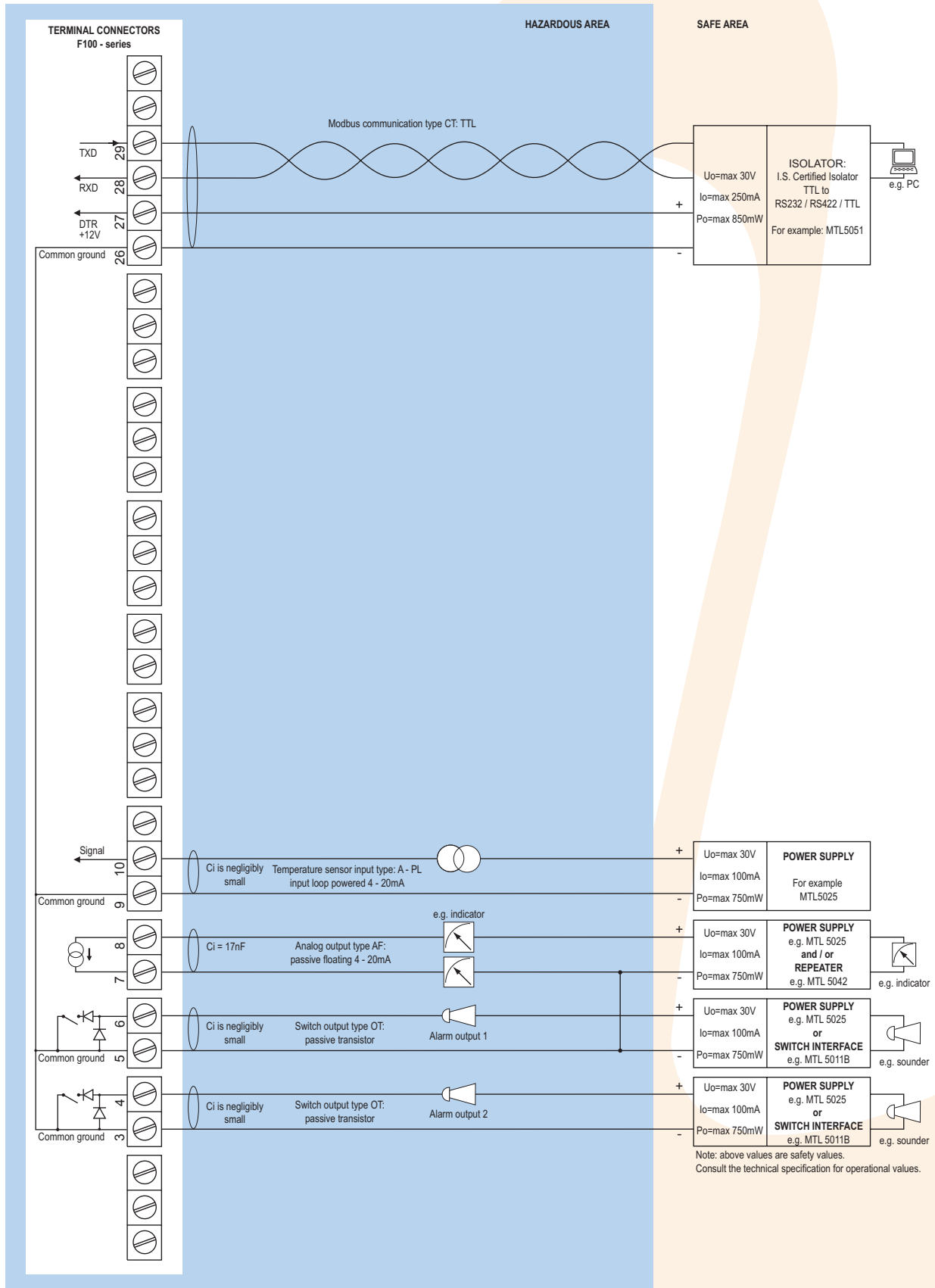

Configuration example IIB and IIC - F143-A-AP-(CT)-OT-PD-XI - Power supply 16 - 30V DC

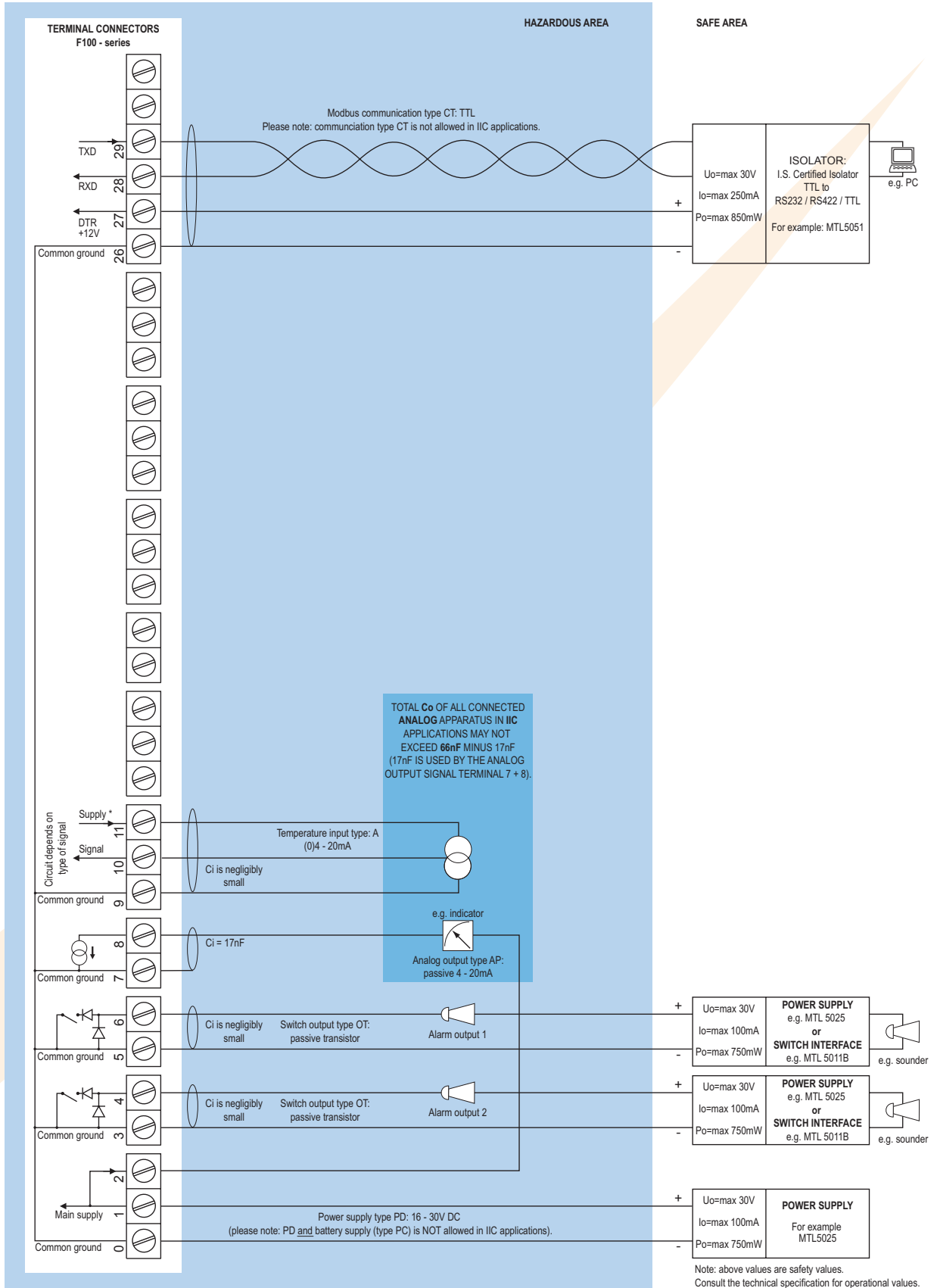

* Note power supply type PD: the supply voltage to sensors is as connected to terminal 1 (internally linked).

Technical specification

General

Display	
Type	High intensity reflective numeric and alphanumeric LCD, UV-resistant.
Dimensions	90 x 40mm (3.5" x 1.6").
Digits	Seven 17mm (0.67") and eleven 8mm (0.31") digits. Various symbols and measuring units.
Refresh rate	User definable: 8 times/sec. - 30 secs.
Option ZB	Transflective LCD with green LED backlight. Good readings in full sunlight and darkness.
Note ZB	Only available for safe area applications.

Operating temperature

Operational	-30°C to +80°C (-22°F to +178°F).
Intrinsically Safe	-30°C to +70°C (-22°F to +158°F).

Power requirements

Type PB	Long life Lithium battery - life-time depends upon settings and configuration - up to 5 years.
Type PC	Intrinsically Safe long life lithium battery - life-time depends upon settings and configuration - up to 5 years.
Type PD	8 - 24V AC / DC ± 10%. Power consumption max. 10 Watt. Intrinsically Safe: 16 - 30V DC; power consumption max. 0.75 Watt.
Type PF	24V AC / DC ± 10%. Power consumption max. 15 Watt.
Type PL	Input loop powered from sensor signal 4 - 20mA (type "A") - requires types AI or AF and OT.
Type PM	115 - 230V AC ± 10%. Power consumption max. 15 Watt.
Type PX	8 - 30V DC. Power consumption max. 0.5 Watt.
Type ZB	12 - 24V DC ± 10% or type PD / PF / PM. Power consumption max. 1 Watt.
Note PB/PF/PM	Not available Intrinsically Safe.
Note PF/PM	The total consumption of the sensors and outputs may not exceed 400mA @ 24V.
Note	For Intrinsically Safe applications, consult the safety values in the certificate.

Sensor excitation

Type PB/PC/PX	3.2V DC.
Note	This is not a real sensor supply. Only suitable for sensors with a very low power consumption.
Type PD	3.2 / 8.2 / 12 / 24V DC - max. 50mA @ 24V DC.
Type PD-XI	The sensor supply voltage will be according to power supply as connected to terminal 1.
Type PF / PM	3.2 / 8.2 / 12 / 24V DC - max. 400mA @ 24V DC.

Terminal connections

Type	Removable plug-in terminal strip. Wire max. 1.5mm ² and 2.5mm ² .
------	---



Data protection

Type	EEPROM backup of all settings. Data retention at least 10 years.
Pass-code	Configuration settings can be pass-code protected.

Environment

Electromagnetic compatibility	Compliant ref: EN 61326 (1997), EN 61010-1 (1993).
-------------------------------	--

Hazardous area

Intrinsically Safe Type XI	ATEX approval ref.:  II 1 GD EEx ia IIB/IIC T4 T100°C. Maximum ambient +70°C (158°F).
Explosion proof Type XF	ATEX approval ref.:  II 2 GD EEx d IIB T5. Dimensions of enclosure: 300 x 250 x 200mm (11.8" x 9.9" x 7.9") L x H x D.
Weight	appr. 15 Kg.

Casing

General

Window	Polycarbonate window.
Sealing	Silicone.
Control keys	Three industrial micro-switch keys. UV-resistant silicone keypad.

Aluminum wall / field mount enclosures

General	Die-cast aluminum wall/field mount enclosure IP67 / NEMA 4X with 2-component UV-resistant coating.
Dimensions	130 x 120 x 75mm (5.12" x 4.72" x 2.95") - W x H x D.
Weight	1100 gr.
Type HA	Cable entry: 2 x PG9 and 1 x M20.
Type HM	Cable entry: 2 x M16 and 1 x M20.
Type HN	Cable entry: 1 x M20.
Type HO	Cable entry: 2 x M20.
Type HP	Cable entry: 6 x M12.
Type HT	Cable entry: 1 x 1/2" NPT.
Type HU	Cable entry: 3 x 1/2" NPT.
Type HZ	Cable entry: no holes.

GRP wall / field mount enclosures

General	GRP wall/field mount enclosure IP67 / NEMA 4X, UV-resistant and flame retardant.
Dimensions	130 x 120 x 75mm (5.12" x 4.72" x 2.95") - W x H x D.
Weight	600 gr.
Type HD	Cable entry: no holes.
Type HE	Cable entry: 2 x Ø 16mm and 1 x Ø 20mm.
Type HF	Cable entry: 1 x Ø 22mm (7/8").
Type HG	Cable entry: 2 x Ø 20mm.
Type HH	Cable entry: 6 x Ø 12mm.
Type HJ	Cable entry: 3 x Ø 22mm (7/8").
Type HK	Flat bottom, cable entry: no holes.

Panel mount enclosures

Dimensions	130 x 120 x 60mm (5.12" x 4.72" x 2.36") - W x H x D.
Panel cut-out	115 x 98mm (4.53" x 3.86") L x H.
Type HB	Die-cast aluminum panel mount enclosure IP65 / NEMA 4.
Weight	600 gr.
Type HC	GRP panel mount enclosure IP65 / NEMA 4, UV-resistant and flame retardant.
Weight	450 gr.

ABS wall / field mount enclosures

General	Silicone free ABS wall/field mount enclosure IP65 with EPDM and PE sealings. UV-resistant polyester keypad (old HD enclosure).
Dimensions	130 x 114 x 71mm (5.1" x 4.5" x 2.8") - W x H x D.
Weight	450 gr.
Type HS	Cable entry: no holes.

Signal inputs

Temperature

Accuracy	Resolution: 14 bit. Error < 0.025mA / ± 0.125% FS. Low level cut-off programmable.
Update time	Four times per second.
Type A	(0)4 - 20mA. Analog input signal can be scaled to any desired range within 0 - 20mA.
Span	0.000010 - 9,999,999 with variable decimal position.
Offset	0.00 - 99,999.99 K.
Voltage drop	2.5V @ 20mA.
Type T	2 or 3 wire PT100.
Range	-100°C to +200°C (-148°F to 392°F). Accuracy 0.1°C (0.18°F).
Option ZV	Range: -200°C to +800°C (-328°F to 1472°F). Accuracy 0.5°C (0.9°F).
Type U	0 - 10V DC. Analog input signal can be scaled to any desired range within 0 - 10V DC.
Span	0.000010 - 9,999,999 with variable decimal position.
Offset	0.00 - 99,999.99 K.
Load impedance	3kΩ.
Note	For signal A and U: power supply to temperature sensor is required; e.g. PD.

Signal outputs

Analog output

Function	Transmitting actual temperature.
Accuracy	10 bit. Error < 0.05%. Analog output signal can be scaled to any desired range.
Update time	Ten times per second.
Type AA	Active 4 - 20mA output (requires OA + PD, PF or PM).
Type AB	Active 0 - 20mA output (requires OA + PD, PF or PM).
Type AF	Passive floating 4 - 20mA output for Intrinsically Safe applications (requires PC, PD or PL).
Type AI	Passive galvanically isolated 4 - 20mA output - also available for battery powered models (requires PB, PD, PF, PL or PM).
Type AP	passive 4 - 20mA output - not isolated. Unit will be loop powered.
Type AU	Active 0 - 10V DC output (requires OA + PD, PF or PM).

Alarm output

Function	User defined: low, low-low, high, high-high or all alarms output.
Type OA	Three active 24V DC transistor outputs (PNP); max. 50mA per output (requires AA + PD, PF or PM).
Type OR	Two electro-mechanical relay outputs isolated (N.O.) - max. switch power 230V AC - 0.5A (requires PF or PM) and one transistor output OT or OA (OA in combination with AA only).
Type OS	Four electro-mechanical relay outputs - isolated; max. switch power 230V AC - 0.5A per relay (requires AP and PD with 24V AC / DC).
Type OT	Three passive transistor outputs (NPN) - not isolated. Max. 50V DC - 300mA per output.
Note	Intrinsically Safe applications: only two transistor outputs type OT available.

Communication option

Function	Reading display information, reading / writing all configuration settings.
Protocol	Modbus ASCII / RTU.
Speed	1200 - 2400 - 4800 - 9600 baud.
Addressing	Maximum 255 addresses.
Type CB	RS232
Type CH	RS485 2-wire
Type CI	RS485 4-wire
Type CT	TTL Intrinsically Safe.

Operational

Operator functions

Displayed functions	<ul style="list-style-type: none"> Actual temperature. Low - low alarm value. Low alarm value. High alarm value. High - high alarm value. Alarm values can be set (or only displayed).
---------------------	--

Temperature

Digits	6 digits.
Units	°C, °F or K.
Decimals	Type T: 1. Type A / U: 3.

Alarm values

Digits	7 digits.
Units	According to the settings for temperature.
Decimals	According to the settings for temperature.
Time units	According to the settings for temperature.
Type of alarm	Low, high, low-low or high-high temperature alarm. Includes alarm delay time and configurable alarm outputs.

Accessories

Mounting accessories

ACFo2	Stainless steel wall mounting kit.
ACFo5	Stainless steel pipe mounting kit (worm gear clamps not included).
ACFo6	Two stainless steel worm gear clamps Ø 44 - 56mm.
ACFo7	Two stainless steel worm gear clamps Ø 58 - 75mm.
ACFo8	Two stainless steel worm gear clamps Ø 77 - 95mm.
ACFo9	Two stainless steel worm gear clamps Ø 106 - 138mm.
ACF10	Customized Grevopal tagplates for ACFo2 and ACFo5, including stainless steel screws. Dimension: 95mm x 12.5mm (3.75" x 0.50").

Cable gland accessories

ACF20	For HA enclosure, includes O-rings.
ACF25	For HE enclosure, includes locknuts and O-rings.
ACF26	For HF enclosure, includes locknuts and O-rings.
ACF27	For HG enclosure, includes locknuts and O-rings.
ACF28	For HH enclosure, includes locknuts and O-rings.
ACF29	For HJ enclosure, includes locknuts and O-rings.
ACF32	For HM enclosure, includes O-rings.
ACF33	For HN enclosure, includes O-rings.
ACF34	For HO enclosure, includes O-rings.
ACF35	For HP enclosure, includes O-rings.
ACF39	For HT enclosure, includes O-rings.
ACF40	For HU enclosure, includes O-rings.

Ordering information

Standard configuration: F143-A-AP-CX-EX-HC-IX-OT-PX-TX-XX-ZX.

Ordering information:	F143	-	A	-	C	-	EX	-	H	-	IX	-	O	-	P	-	TX	-	X	-	Z
Temperature signal																					
A	⊗		(0)4 - 20mA input.																		
T	⊗		PT100 input.																		
U	⊗		0 - 10V DC input.																		
Analog output signal																					
AA			Active 4 - 20mA output - requires OA + PD, PF or PM.																		
AB			Active 0 - 20mA output - requires OA + PD, PF or PM.																		
AF	⊗		I.S. floating 4 - 20mA output - requires PC, PD or PL.																		
AI			Isolated 4 - 20mA output - requires PB, PD, PF, PL or PM.																		
AP	⊗		Passive 4 - 20mA output, loop powered unit.																		
AU			Active 0 - 10V DC output - requires OA + PD, PF or PM.																		
Communication																					
CB			Communication RS232 - Modbus ASCII / RTU.																		
CH			Communication RS485 - 2-wire - Modbus ASCII / RTU.																		
CI			Communication RS485 - 4-wire - Modbus ASCII / RTU.																		
CT	⊗		Intrinsically Safe TTL - Modbus ASCII / RTU.																		
CX	⊗		No communication.																		
Flow equations																					
EX	⊗		No flow equations.																		
Panel mount enclosures - IP65 / NEMA4																					
HB	⊗		Aluminum enclosure.																		
HC	⊗		GRP enclosure.																		
GRP field / wall mount enclosures - IP67 / NEMA4X																					
HD	⊗		Cable entry: no holes.																		
HE	⊗		Cable entry: 2 x Ø 16mm & 1 x Ø 20mm.																		
HF	⊗		Cable entry: 1 x Ø 22mm (7/8").																		
HG	⊗		Cable entry: 2 x Ø 20mm.																		
HH	⊗		Cable entry: 6 x Ø 12mm.																		
HJ	⊗		Cable entry: 3 x Ø 22mm (7/8").																		
HK	⊗		Flat bottom, cable entry: no holes.																		
Aluminum field / wall mount enclosures - IP67 / NEMA4X																					
HA	⊗		Cable entry: 2 x PG9 + 1 x M20.																		
HM	⊗		Cable entry: 2 x M16 + 1 x M20.																		
HN	⊗		Cable entry: 1 x M20.																		
HO	⊗		Cable entry: 2 x M20.																		
HP	⊗		Cable entry: 6 x M12.																		
HT	⊗		Cable entry: 1 x 1/2" NPT.																		
HU	⊗		Cable entry: 3 x 1/2" NPT.																		
HZ	⊗		Cable entry: no holes.																		
ABS field / wall mount enclosures																					
HS	⊗		Silicone free ABS field enclosure IP65 – Cable entry: no holes (old HD enclosure).																		
Additional inputs																					
IX	⊗		No additional input.																		
Outputs																					
OA			Three active transistor outputs - requires AA, AB or AU and PD, PF or PM.																		
OR			Two mechanical relay outputs + one OT or OA - requires PF or PM.																		
OS			Four mechanical relay outputs - requires AP and PD.																		
OT	⊗		Three passive transistor outputs - standard configuration.																		
Power supply																					
PB			Lithium battery powered.																		
PC	⊗		Lithium battery powered - Intrinsically Safe.																		
PD	⊗		8 - 24V AC / DC + sensor supply - with XI: 16 - 30V DC.																		
PF			24V AC / DC + sensor supply.																		
PL	⊗		Input loop powered from sensor signal type "A" - requires AI or AF and OT.																		
PM			115 - 230V AC + sensor supply.																		
PX	⊗		Basic power supply 8 - 30V DC (no real sensor supply). Unit requires external loop AP.																		
Temperature input signal																					
TX	⊗		No temperature input signal.																		
Hazardous area																					
XI	⊗		Intrinsically Safe.																		
XF			EExd enclosure - 3 keys.																		
XX			Safe area only.																		
Other options																					
ZB			Backlight.																		
ZV	⊗		PRTD-range -200°C / +800°C.																		
ZX	⊗		No options.																		

The bold marked text contains the standard configuration.

⊗ Available Intrinsically Safe.

Specifications are subject to change without notice.